



CRAWFORD COUNTY
501 Norway Street
Suite #1
Grayling, MI 49738
(989) 348-7800

KALKASKA COUNTY
625 Courthouse Drive
Kalkaska, MI 49646
(231) 258-8669

LAKE COUNTY
5681 S. M-37
Baldwin, MI 49304
(231) 745-4663

MANISTEE COUNTY
385 Third Street
Manistee, MI 49660
(231) 723-3595

MASON COUNTY
916 Diana Street
Ludington, MI 49431
(231) 845-7381

MECOSTA COUNTY
14485 Northland Drive
Big Rapids, MI 49307
(231) 592-0130

MISSAUKEE COUNTY
6180 W. Sanborn Road
Suite #1
Lake City, MI 49651
(231) 839-7167

NEWAYGO COUNTY
PO Box 850
1049 Newell Street
White Cloud, MI 49349
(231) 689-7300

OCEANA COUNTY
3986 N. Oceana Drive
Hart, MI 49420
(231) 873-2193

WEXFORD COUNTY
521 Cobb Street
Cadillac, MI 49601
(231) 775-9942



www.dhd10.org



www.facebook.com/DHD10

April 13, 2020

Dear Businesses and Organizations:

On April 9, 2020, Governor Whitmer released [Executive Order No. 2020-42](#) for the temporary requirement to suspend activities that are not necessary to sustain or protect life. This order is in effect until April 30, 2020. There are several businesses within our ten-county jurisdiction that remain open because they are considered essential services to our critical infrastructure.

District Health Department #10 developed this Business Toolkit to provide guidance for essential businesses that are still operating during the COVID-19 pandemic. Inside it you will find:

1. Interim guidance from the CDC for Critical Infrastructure Workers who may have been exposed to COVID-19
2. Coronavirus (COVID-19) workplace checklist
3. Managing Coronavirus (COVID-19) in the workplace
4. Coronavirus (COVID-19) workplace health screening forms
5. Directions for social distancing, self-monitoring, self-quarantine, and self-isolation
6. Cleaning and disinfection for facilities after suspected or confirmed COVID-19 Exposure
7. Instructions for cloth face coverings

Should you need further guidance or have additional questions, please contact us at 231-876-3823 or email us at info@dhd10.org.

To your health,

Kevin Hughes
Health Officer
District Health Department #10

Interim Guidance for Implementing Safety Practices for Critical Infrastructure Workers Who May Have Had Exposure to a Person with Suspected or Confirmed COVID-19

To ensure continuity of operations of essential functions, CDC advises that critical infrastructure workers may be permitted to continue work following potential exposure to COVID-19, provided they remain asymptomatic and additional precautions are implemented to protect them and the community.

A potential exposure means being a household contact or having close contact within 6 feet of an individual with confirmed or suspected COVID-19. The timeframe for having contact with an individual includes the period of time of 48 hours before the individual became symptomatic.

Critical Infrastructure workers who have had an exposure but remain asymptomatic should adhere to the following practices prior to and during their work shift:

- ▶ **Pre-Screen:** Employers should measure the employee's temperature and assess symptoms prior to them starting work. Ideally, temperature checks should happen before the individual enters the facility.
- ▶ **Regular Monitoring:** As long as the employee doesn't have a temperature or symptoms, they should self-monitor under the supervision of their employer's occupational health program.
- ▶ **Wear a Mask:** The employee should wear a face mask at all times while in the workplace for 14 days after last exposure. Employers can issue facemasks or can approve employees' supplied cloth face coverings in the event of shortages.
- ▶ **Social Distance:** The employee should maintain 6 feet and practice social distancing as work duties permit in the workplace.
- ▶ **Disinfect and Clean work spaces:** Clean and disinfect all areas such as offices, bathrooms, common areas, shared electronic equipment routinely.

If the employee becomes sick during the day, they should be sent home immediately. Surfaces in their workspace should be cleaned and disinfected. Information on persons who had contact with the ill employee during the time the employee had symptoms and 2 days prior to symptoms should be compiled. Others at the facility with close contact within 6 feet of the employee during this time would be considered exposed.

Employers should implement the recommendations in the Interim Guidance for Businesses and Employers to Plan and Respond to Coronavirus Disease 2019 to help prevent and slow the spread of COVID-19 in the workplace. Additional information about identifying critical infrastructure during COVID-19 can be found on the DHS CISA website or the CDC's specific First Responder Guidance page.

INTERIM GUIDANCE

This interim guidance pertains to critical infrastructure workers, including personnel in 16 different sectors of work including:

- ▶ Federal, state, & local law enforcement
- ▶ 911 call center employees
- ▶ Fusion Center employees
- ▶ Hazardous material responders from government and the private sector
- ▶ Janitorial staff and other custodial staff
- ▶ Workers – including contracted vendors – in food and agriculture, critical manufacturing, informational technology, transportation, energy and government facilities

ADDITIONAL CONSIDERATIONS

- ▶ Employees should not share headsets or other objects that are near mouth or nose.
- ▶ Employers should increase the frequency of cleaning commonly touched surfaces.
- ▶ Employees and employers should consider pilot testing the use of face masks to ensure they do not interfere with work assignments.
- ▶ Employers should work with facility maintenance staff to increase air exchanges in room.
- ▶ Employees should physically distance when they take breaks together. Stagger breaks and don't congregate in the break room, and don't share food or utensils.



Coronavirus Disease (COVID-19) Workplace Checklist



District Health Department #10 businesses and entities may remain open if they provide essential services to sustaining or protecting life. On April 9, 2020, Governor Whitmer released [Executive Order No. 2020-42](#) for the temporary requirement to suspend activities that are not necessary to sustain or protect life. This order is in effect until April 30, 2020. These businesses and entities must take the following actions to ensure the safety of employees and customers.

Screen staff reporting to work sites

Employers should measure employee's temperature and assess symptoms prior to starting work. Ask employee the following question:

1. Do you have symptoms of fever, cough, shortness of breath, sore throat, or diarrhea?

If an employee answers **YES**, you should:

Send the employee home immediately. The employee should self-isolate/self-quarantine at home for:

- If symptoms are present, a minimum of 7 days since symptoms first appear. Must also have 3 days without fevers and improvement in respiratory symptoms.

Screening Guidance:

Create and implement an active screening plan that will work best for your facility. Determine where and how this screening will take place. You can use the form included in this packet to record answers. You are not required to record answers to the 3 screening questions, or record employee temperature results. We recommend it, but you are not required to do so.

Items to consider: Stagger shift starting times so employees do not arrive at the same time. Have one person asking staff these questions directly. Or, staff could do a "self-check-in" by entering their information on a computer, tablet, or sheet of paper. Be sure to instruct employees on properly disinfecting equipment or writing utensils. Provide alcohol-based hand sanitizer at the screening station, if possible.

If a touchless/contactless thermometer is available, a temperature check is strongly recommended at the worksite. We understand it may be difficult to get a thermometer at this time. Employees can also take their temperature at home and report it to their employer. A fever is considered a temperature of 100.4°F or above.

If your facility is already following other appropriate or more-stringent infection control procedures (like CDC guidelines), please continue to use those procedures.

Note that the 14 day quarantine period does not apply to hospitals, healthcare facilities, EMS, other organizations that employ healthcare workers in the inpatient or outpatient setting, all providers and support staff involved in patient care, and public health staffing actively involved in the COVID-19 response (local or state).

Develop and implement a social distancing plan

Determine how you will maintain 6 feet of distance between people. This 6-foot distance applies to employees working in shared spaces, and to customers waiting for services inside or outside the business. Options include using signs, contact barriers, entrance limits, and specialized hours. You may also need to limit capacity inside facilities to provide for social distancing between customers and employees.

For questions, visit www.dhd10.org/coronavirus or contact District Health Department #10 at info@dhd10.org

Managing Coronavirus Disease (COVID-19) in the Workplace



For essential businesses and organizations that continue to operate during the COVID-19 pandemic, District Health Department #10 recommends:

- Screen everyone. Check employees for fever or other symptoms if they will enter facilities or buildings.
- Maintain 6 feet of distance between people.
- Emphasize frequent and proper hand washing. Make sure sinks are well supplied.
- Work remotely whenever possible.
- Do not share space or equipment. If this is not possible, have employees wash their hands before and after using shared equipment. Clean and sanitize equipment between uses.
- Any employee with cold symptoms or underlying health conditions should stay home or work remotely.

What do I do when my employee shows up to work ill?

If an employee comes to work ill, or becomes ill while at work, they should be directed to go home immediately and **self-quarantine**, even if their symptoms are mild. If they are having trouble breathing or cannot keep fluids down, have them contact their doctor right away. COVID-19 symptoms are very similar to the symptoms seen in a typical cold or flu. However, it is best to be cautious. Take care not to over-react in order to prevent panic among your team. Consider alternative work options like teleworking if your employee is well enough to do so.

What should I do if visitors or customers have symptoms of illness, such as coughing or sneezing?

You and your employees should follow social distancing guidance and maintain at least a 6-foot distance from anyone, especially those who are having symptoms. If your employee must be closer to the customer, advise them to minimize time spent with symptomatic customers to less than 10 minutes, if possible. Be sure to provide the public with tissues and trash receptacles. Have a no-touch hand sanitizer dispenser near customer entrances, if feasible.

One of our employees just tested positive for COVID-19. What should I do?

Instruct the employee to stay home and **self-isolate**. They should not return to work for at least 7 days after symptoms first started and 72 hours after fever has resolved without the use of fever-reducing medicines and symptoms have improved, whichever is longer. Offer telework assignments if the employee is well enough to work. **IMPORTANT:** You must protect the confidentiality of your employee. Legally, you cannot identify the employee by name. DO NOT disclose to other staff or third persons the name or other personal or health information of the employee who tested positive for COVID-19.

Thoroughly clean and disinfect equipment and other elements of the work environment of the employee along with frequently touched surfaces and objects such as doorknobs/pushbars, elevator buttons, restroom doors, etc. Use EPA-approved disinfectants and use according to label instructions.

If the employee had been working while ill, identify co-workers and individuals that the employee may have come into contact with and advise them to **self-monitor** their symptoms. If employees who may have been exposed to an ill individual do not have symptoms, they can continue working but must adhere to social distancing guidelines, wear a mask the entire day, and disinfect and clean their workspace. Common areas, including bathrooms and break rooms, should be disinfected as well. If an employee starts to have symptoms during the workday, send them home immediately. Track exposed employees on the form provided and regularly monitor them for symptoms.

One of our employee's family members has a "suspected" (but unconfirmed) case of COVID-19. What should we do?

Employees who have had close contact to a suspect or known case of COVID-19 can continue working but should **self-monitor** their symptoms and adhere to social distancing guidelines, wear a mask the entire day, and disinfect and clean their workspace. Common areas, including bathrooms and break rooms, should be disinfected as well. If an employee starts to have symptoms during the workday, send them home immediately. Track exposed employees on the form provided and regularly monitor them for symptoms.

One of our employees has a "suspected" (but unconfirmed) case of COVID-19. Should I send everyone home?

You would follow all the same steps outlined above for an employee who tested positive for COVID-19. If employees who may have been exposed to an ill individual do not have symptoms, they can continue working but must continue to **self-monitor** their symptoms, adhere to social distancing guidelines, wear a mask the entire day, and disinfect and clean their workspace. Common areas, including bathrooms and break rooms, should be disinfected as well. If an employee starts to have symptoms during the workday, send them home immediately. Track exposed employees on the form provided and regularly monitor them for symptoms.

One of my employees has self-reported that they came into contact with someone believed to be positive for COVID-19. What should I do?

Review the nature of the exposure. They can continue working but must **self-monitor** their symptoms, adhere to social distancing guidelines, wear a mask the entire day, and disinfect and clean their workspace. Common areas, including bathrooms and break rooms, should be disinfected as well. If an employee starts to have symptoms during the workday, send them home immediately. Track exposed employees on the form provided and regularly monitor them for symptoms.

One of our employees just found out that they were exposed to COVID-19 after interacting with a member of the public (or vendor, or contractor). What steps do I take?

Review the nature of the exposure. They can continue working but must **self-monitor** their symptoms, adhere to social distancing guidelines, wear a mask the entire day, and disinfect and clean their workspace. Common areas, including bathrooms and break rooms, should be disinfected as well. If an employee starts to have symptoms during the workday, send them home immediately. Track exposed employees on the form provided and regularly monitor them for symptoms.

When can my employee come back to work if they have been ill?

Employees who have been ill with symptoms of an upper respiratory illness [new onset of fever (subjective or temperature of $\geq 100.4^{\circ}\text{F}$ or 37.8°C) OR symptoms of possible COVID-19 (cough OR shortness of breath OR sore throat)] can return to work 7 days after symptoms started and 72 hours after fevers have resolved without the use of fever reducing medications and symptoms improved, whichever is longer.

Please refer to the guidelines for Social Distancing, Self-Monitoring, and Self-Isolation on the subsequent pages. For additional guidance, please go to:

- District Health Department #10: www.dhd10.org/coronavirus
- Michigan: michigan.gov/coronavirus
- National: cdc.gov/COVID19

Coronavirus Disease (COVID-19 Workplace Health Screening)

Company Name: _____

Employee Name: _____

Date: _____

Time In: _____

In the past 24 hours, have you experienced:

Subjective fever (felt feverish): Yes No

New or worsening cough: Yes No

Shortness of breath: Yes No

Sore throat: Yes No

Vomiting/Diarrhea: Yes No

Current temperature: _____

If you answer “yes” to any of the symptoms listed above, or your temperature is 100.4 °F or higher, please do not go into work. Self-isolate at home and contact your primary care physician’s office for direction.

- You should isolate at home for minimum of 7 days since symptoms first appear.
- You must also have 3 days without fevers and improvement in respiratory symptoms

Have you had close contact in the last 14 days with an individual diagnosed with COVID-19? Yes No

Have you engaged in any activity or travel within the last 14 days which fails to comply with the *Stay Home, Stay Safe* Executive Order? Yes No

Have you been directed or told by the local health department or your healthcare provider to self-isolate or self-quarantine? Yes No

If you answer “yes” to either of these questions, please do not go into work. Self-quarantine at home for 14 days.

Directions for Social Distancing, Self-Monitoring, Self-Quarantine, and Self-Isolation

Social Distancing

- Keep 6 feet of space between people as much as possible
- Avoid places at their busiest times
- Use online, drive-through or curbside services when possible
- Avoid getting together in large social groups
- If possible, businesses should have employee tele-commute, provide online options and limit in-person meetings
- Wear a face mask at all times while in the workplace. Employers can issue face masks or can approve employees' supplied cloth face coverings in the event of shortages.

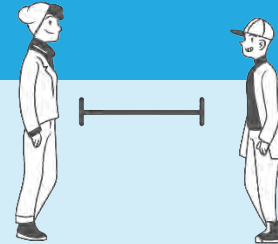

Self-Monitoring



- Practice social distancing.
- Take and record temperature twice a day, once in the morning and once in the evening.
- Report any temperature of 100.4 °F or above to your doctor.
- Report any onset of respiratory illness to your doctor. These include:
 1. Cough
 2. Shortness of breath or difficulty breathing
 3. Chest pain
 4. Additionally, you could experience sore throat, muscle aches, chills, headache, abdominal pain, nausea, vomiting or diarrhea
- If you need medical care, call ahead to your doctor.
- Household members should practice social distancing.
- If you develop symptoms of illness you will move into Self-Isolation (see page 3).

Self-Quarantine



- Under no circumstance should you go to work, school or public places. You should only consider leaving your home if you need medical attention.
 - Avoid using public transportation to get to your medical provider or emergency department. Do not use busses, Uber, Lyft, taxi cabs or rail lines.
 - Wear a mask over your nose and mouth if you must leave your house to seek medical care.
- Take and record temperature twice a day, once in the morning and once in the evening.
- Report any temperature of 100.4°F or above to your doctor.
- Report any onset of respiratory illness to your doctor. These include:
 1. Cough
 2. Shortness of breath or difficulty breathing
 3. Chest pain
 4. Additionally, you could experience sore throat, muscle aches, chills, headache, abdominal pain, nausea, vomiting or diarrhea
- If you need medical care, call ahead to your doctor.
- Minimize contact with others in your home when possible.
- Do not share items with your household members or pets such as dishes, drinking cups, silverware, towels or bedding. After using these items, they should be washed with soap and hot water.
- Cover your coughs and sneezes with a disposable tissue or the upper part of your sleeve. Dispose of tissues in a lined trash can. Wash your hand immediately afterward.
- Wash your hands frequently with soap and water for at least 20 seconds. This includes after using the restroom, coughing or sneezing, or when they are visibly dirty. If you do not have access to soap and water, use a hand sanitizer with 60% to 95% alcohol.
- Avoid touching your eyes, nose and mouth with unwashed hands.
- Clean your frequently used surfaces with a solution of ¼ cup bleach to a gallon of water or disinfectant sprays or wipes daily. This includes “high-touch” surfaces such as phones, tablets, keyboards, doorknobs, bathroom fixtures, toilets, counters, tabletops and bedside tables. Wear rubber gloves if necessary and make sure the area is properly ventilated.
- Household members should practice self-monitoring.

Self-Isolation



- **Under no circumstance should you go to work, school or public places.** You should only consider leaving your home if you need medical attention.
 - Avoid using public transportation to get to your medical provider or emergency department. Do not use busses, Uber, Lyft, or taxi cabs.
 - Wear a mask over your nose and mouth if you must leave your house to seek medical care.
- Avoid handling pets or other animals while you are sick.
- Cover your coughs and sneezes with a disposable tissue or the upper part of your sleeve. Dispose of tissues in a lined trash can. Wash your hands immediately afterward.
- Wash your hands frequently with soap and water for at least 20 seconds. This includes after using the restroom, coughing or sneezing, or when they are visibly dirty. If you do not have access to soap and water, use a hand sanitizer with 60% - 95% alcohol.
- Avoid touching your eyes, nose and mouth with unwashed hands.
- Clean your frequently used surfaces with a solution of ¼ cup bleach to a gallon of water or disinfectant sprays or wipes daily. This includes “high-touch” surfaces such as phones, tablets, keyboards, doorknobs, bathroom fixtures, toilets, counters, tabletops and bedside tables. Wear rubber gloves if necessary and make sure the area is properly ventilated.
- Clean any item or surface that may have blood, mucus, vomit, urine, stool or other body fluids on them.
- Make sure your home has good airflow, open windows if weather permits or use the air conditioner.

If you live with others:

- Separate yourself from other household members and pets whenever possible.
 - You should stay in a specific room and away from other household members.
 - Use a separate bathroom if possible.
 - If you must share a bathroom wipe down all surfaces after the patient uses it. Separate toothbrushes.
 - If you share a shower, do not share razors, washcloths or body sponges/poufs
 - If you must enter a shared space put a mask over your nose and mouth before leaving your room
- Do not share items with your household members or pets such as dishes, drinking cups, silverware, towels or bedding. After using these items, they should be washed with soap and hot water
- Household members should practice Self-quarantine (see page 2)

If you live alone:

- Do not open your door to anyone. If someone is dropping off groceries or other items for you, have them leave it at your doorstep and wait until they leave to open the door.
- Do not cook food for anyone other than yourself

When seeking care at a healthcare facility:

- Call ahead to get direction from your health care provider. They may ask you to meet them outside or usher you into a different entrance than the general public uses
- Avoid using public transportation to get to your medical provider or emergency department. Do not use busses, Uber, Lyft, taxi cabs or rail lines.
 - If you are unable to drive yourself and do not have a ride, call 9-1-1 for transport by ambulance
 - If someone is giving you a ride, wear a mask that covers your mouth and nose while you are in the vehicle with them
- If you are driving yourself, apply a mask that covers your mouth and nose before exiting your vehicle

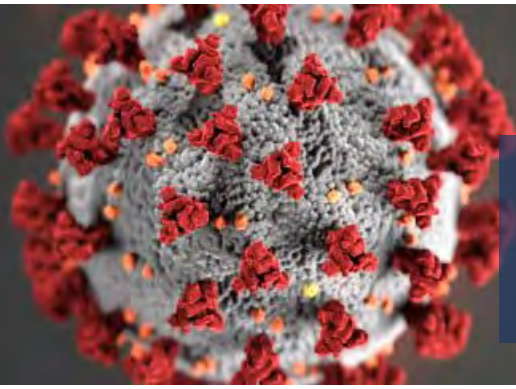

CLEANING & DISINFECTION

For Facilities After Suspected or Confirmed COVID-19 Exposure

Michigan.gov/Coronavirus

Timing and location of cleaning and disinfection of surfaces.

At a school, daycare center, office, or other facility that **does not house people overnight**:

It is recommended to close off areas used by the ill persons and wait as long as practical before beginning cleaning and disinfection to minimize potential for exposure to respiratory droplets. Open outside doors and windows to increase air circulation in the area. If possible, wait up to 24 hours before beginning cleaning and disinfection.

How to clean and disinfect.

Surfaces

If surfaces are dirty, they should be cleaned using a detergent or soap and water prior to disinfection.

For disinfection, diluted household bleach solutions, alcohol solutions with at least 70% alcohol, and most common EPA-registered household disinfectants should be effective.

- Diluted household bleach solutions can be used if appropriate for the surface. Follow manufacturer's instructions for application and proper ventilation.
- Check to ensure the product is not past its expiration date. Never mix household bleach with ammonia or any other cleanser.

- Unexpired household bleach will be effective against coronaviruses when properly diluted.

Prepare a bleach solution by mixing:

- Five tablespoons (1/3 cup) bleach per gallon of water, or
- Four teaspoons bleach per quart of water.

[Products with EPA-approved emerging viral pathogens claims](#) are expected to be effective against COVID-19 based on data for harder to kill viruses. Follow the manufacturer's instructions for all cleaning and disinfection products (e.g., concentration, application method and contact time, etc.).

Soft Surfaces

For soft (porous) surfaces such as carpeted floor, rugs, and drapes, remove visible contamination if present and clean with appropriate cleaners indicated for use on these surfaces. After cleaning:

- If the items can be laundered, launder items in accordance with the manufacturer's instructions using the warmest appropriate water setting for the items and then dry items completely. Otherwise, use products with the EPA-approved emerging viral pathogens claims [that are suitable for porous surfaces](#).

Linens, Clothing, and Other Items That Go in the Laundry

- Do not shake dirty laundry; this minimizes the possibility of dispersing virus through the air.
- Wash items as appropriate in accordance with the manufacturer's instructions. If possible, launder items using the warmest appropriate water setting for the items and dry items completely. Dirty laundry that has been in contact with an ill person can be washed with other people's items.
- Clean and disinfect hampers or other carts for transporting laundry according to guidance above for hard or soft surfaces.

Personal protective equipment (PPE) and hand hygiene considerations.

Cleaning staff should wear disposable gloves and gowns for all tasks in the cleaning process, including handling trash.

- Gloves and gowns should be compatible with the disinfectant products being used.
- Additional PPE might be required based on the cleaning/disinfectant products being used and whether there is a risk of splash.
- Gloves and gowns should be removed carefully to avoid contamination of the wearer and the surrounding area. Be sure to **clean hands** after removing gloves.
- Gloves should be removed after cleaning a room or area occupied by ill persons. [Clean hands](#) immediately after gloves are removed.
- Cleaning staff should immediately report breaches in PPE (e.g., tear in gloves) or any potential exposures to their supervisor.

Cleaning staff and others should clean hands often.

Clean hands often including immediately after removing gloves and after contact with an ill person, by washing hands with soap and warm water for 20 seconds. If soap and warm water are not available and hands are not visibly dirty, an alcohol-based hand sanitizer that contains at least 60% alcohol may be used. However, if hands are visibly dirty, always wash hands with soap and warm water.

Follow normal preventive actions while at work and home, including cleaning hands and avoiding touching eyes, nose, or mouth. Additional key times to clean hands include:

- After blowing one's nose, coughing, or sneezing
- After using the restroom
- Before eating or preparing food
- After contact with animals or pets
- Before and after providing routine care for another person who needs assistance (e.g., a child)

Use of Cloth Face Coverings to Help Slow the Spread of COVID-19

How to Wear Cloth Face Coverings

Cloth face coverings should—

- fit snugly but comfortably against the side of the face
- be secured with ties or ear loops
- include multiple layers of fabric
- allow for breathing without restriction
- be able to be laundered and machine dried without damage or change to shape

CDC on Homemade Cloth Face Coverings

CDC recommends wearing cloth face coverings in public settings where other social distancing measures are difficult to maintain (e.g., grocery stores and pharmacies), **especially** in areas of significant community-based transmission.

CDC also advises the use of simple cloth face coverings to slow the spread of the virus and help people who may have the virus and do not know it from transmitting it to others. Cloth face coverings fashioned from household items or made at home from common materials at low cost can be used as an additional, voluntary public health measure.

Cloth face coverings should not be placed on young children under age 2, anyone who has trouble breathing, or is unconscious, incapacitated or otherwise unable to remove the cloth face covering without assistance.

The cloth face coverings recommended are not surgical masks or N-95 respirators. Those are critical supplies that must continue to be reserved for healthcare workers and other medical first responders, as recommended by current CDC guidance.

Should cloth face coverings be washed or otherwise cleaned regularly? How regularly?

Yes. They should be routinely washed depending on the frequency of use.

How does one safely sterilize/clean a cloth face covering?

A washing machine should suffice in properly washing a cloth face covering.

How does one safely remove a used cloth face covering?

Individuals should be careful not to touch their eyes, nose, and mouth when removing their cloth face covering and wash hands immediately after removing.

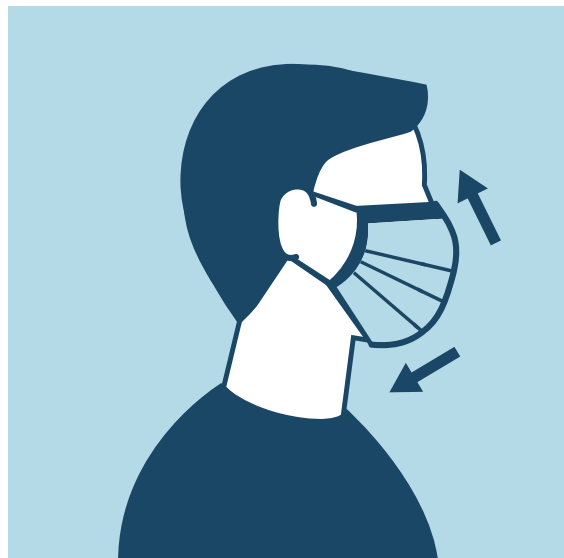

Sewn Cloth Face Covering

Materials

- Two 10"x6" rectangles of cotton fabric
- Two 6" pieces of elastic (or rubber bands, string, cloth strips, or hair ties)
- Needle and thread (or bobby pin)
- Scissors
- Sewing machine

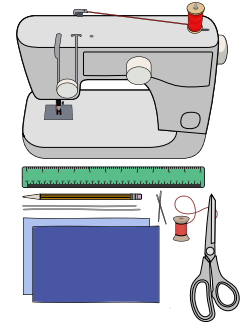

Tutorial

1. Cut out two 10-by-6-inch rectangles of cotton fabric. Use tightly woven cotton, such as quilting fabric or cotton sheets. T-shirt fabric will work in a pinch. Stack the two rectangles; you will sew the cloth face covering as if it was a single piece of fabric.

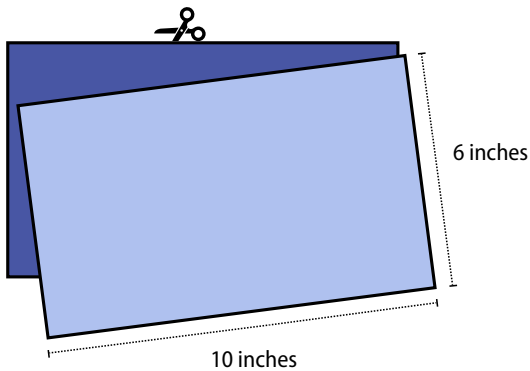

2. Fold over the long sides $\frac{1}{4}$ inch and hem. Then fold the double layer of fabric over $\frac{1}{2}$ inch along the short sides and stitch down.

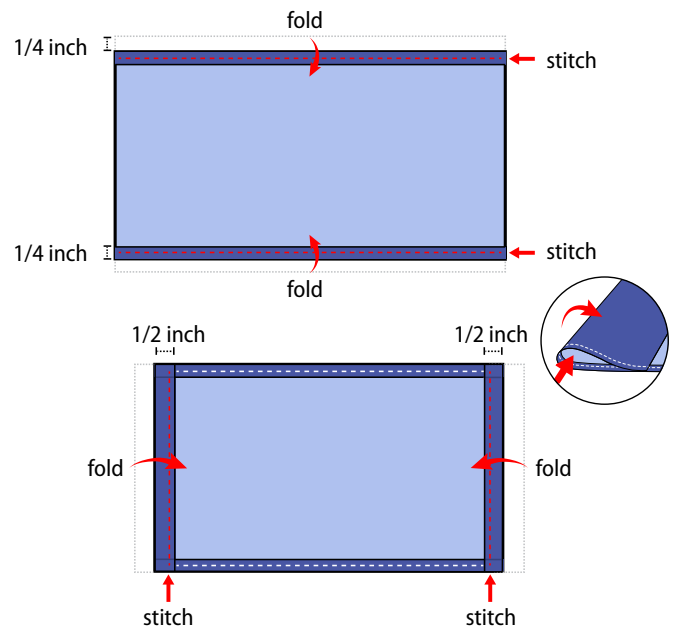

3. Run a 6-inch length of $\frac{1}{8}$ -inch wide elastic through the wider hem on each side of the cloth face covering. These will be the ear loops. Use a large needle or a bobby pin to thread it through. Tie the ends tight. Don't have elastic? Use hair ties or elastic head bands. If you only have string, you can make the ties longer and tie the cloth face covering behind your head.

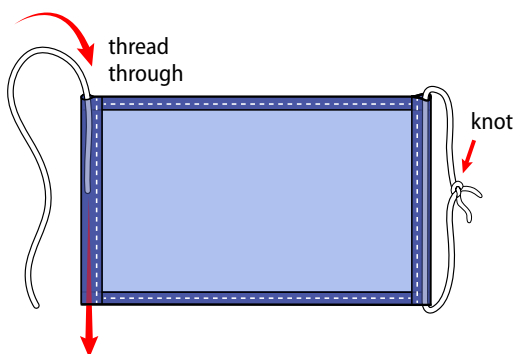

4. Gently pull on the elastic so that the knots are tucked inside the hem. Gather the sides of the cloth face covering on the elastic and adjust so the cloth face covering fits your face. Then securely stitch the elastic in place to keep it from slipping.

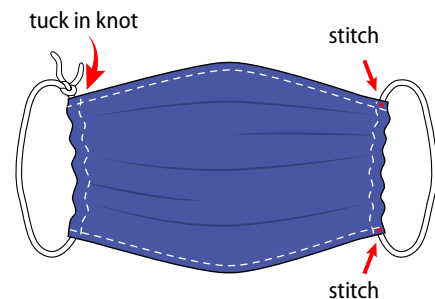

Quick Cut T-shirt Cloth Face Covering (no sew method)

Materials

- T-shirt
- Scissors

Tutorial

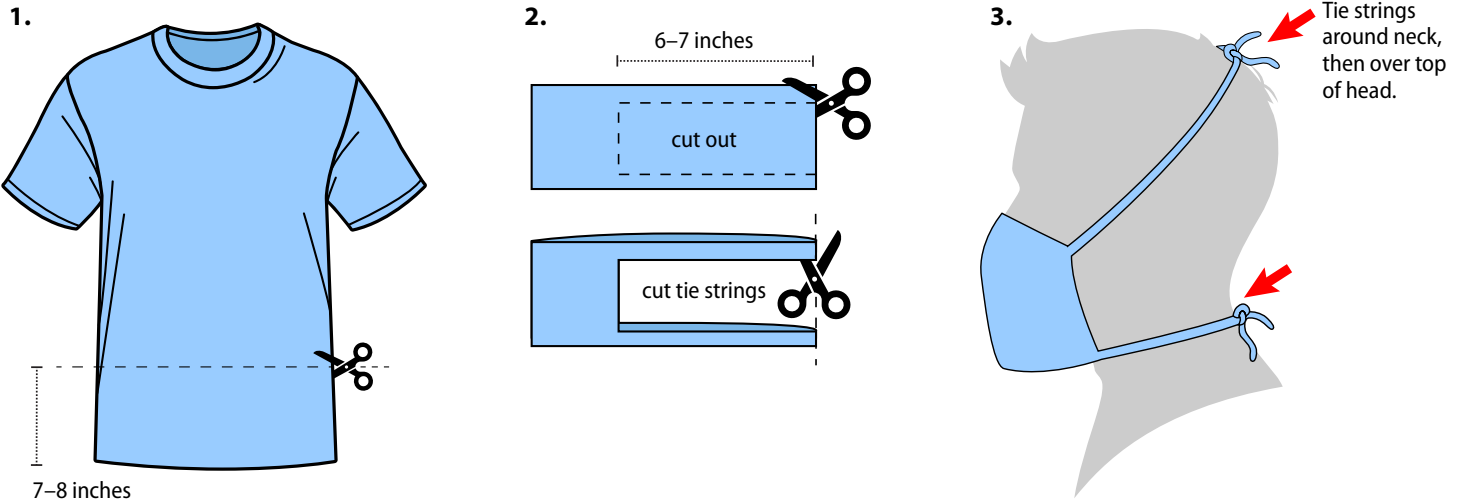

Bandana Cloth Face Covering (no sew method)

Materials

- Bandana (or square cotton cloth approximately 20"x20")
- Coffee filter
- Rubber bands (or hair ties)
- Scissors (if you are cutting your own cloth)

Tutorial

